

# 液体称量型送料机 LWF

## Liquid Weighing Feeder LWF



### 适应 Applications

|                                      |  |
|--------------------------------------|--|
| 适应材料<br>Applicable materials         | 纯水、阻燃剂、润滑剂、抗氧化剂、防静电剂等各种液体。<br>Various liquids such as demineralized water, flame retardant, lubricant, oxidation inhibitor and anti-static agent |
| 温度<br>Temperature                    | 常温~最大120℃保温<br>Room temperature to maximum 120°C thermal retention   |
| 最大供液压力<br>Maximum discharge pressure | 7MPa(齿轮泵)、15MPa(柱塞泵)<br>7 MPa (gear pump), 15 MPa (plunger pump)   |

### 主规格(齿轮泵型标准规格\*) Principal specifications (Gear pump type standard specifications)\*

| 型号<br>Model | 流量范围(L/h)<br>Flow rate range (L/h) | 计量罐容量(L)<br>Hopper capacity (L) | 称量(kg)<br>Weighing capacity (kg) | 产品重量(kg)<br>Feeder weight (kg) | 电源<br>Power supply  |
|-------------|------------------------------------|---------------------------------|----------------------------------|--------------------------------|---|
| CE-L-1D     | 0.1~180                            | 25                              | 25                               | 约120<br>Approx. 120            | AC380V 3相<br>动力1.5~4.5KVA<br>加热器2KVA<br>380V AC, 3 phase,<br>power line 1.5 to 4.5<br>kVA, heater 2 kVA |
| CE-L-2D     | 3~270                              | 50                              | 50                               | 约150<br>Approx. 150            | AC380V 3相<br>动力1.5~11KVA<br>加热器3KVA<br>380V AC, 3 phase,<br>power line 1.5 to 11<br>kVA, heater 3 kVA   |
| CE-L-3D     | 5~540                              | 100                             | 100                              | 约210<br>Approx. 210            | AC380V 3相<br>动力1.5~11KVA<br>加热器3KVA<br>380V AC, 3 phase,<br>power line 1.5 to 11<br>kVA, heater 3 kVA   |

\*齿轮泵适用于粘度为100cP以上的液体。未达到100cP的场合,改用柱塞泵或其他方式。  
\*Gear pump will be selected for the liquid with its viscosity over 100cP. For the liquid with its viscosity under 100cP, another feeding methods like plunger pump will be selected.

### 外形尺寸 Dimensions

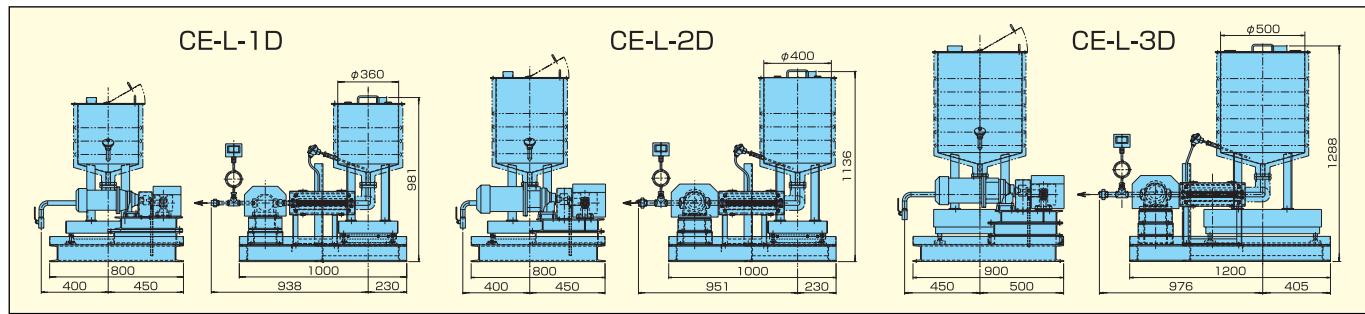

### 周边装置 Peripherals

#### 标准配置

- 集油托盘 防止液体洒到地上。
- 压力开关 监测供液压力。
- 测温罐内液温用热电偶 计测量罐内的液体温度。
- 齿轮泵加热器及保温套 保持液体温度在一定值。
- 挠性软管加热器及保温套 保持液体温度在一定值。
- 计量罐加热器及保温套 保持液体温度在一定值。

#### Standard devices

- Oil pan Prevents liquids from spilling on floor.
- Pressure switch Measures discharge pressure.
- Liquid temperature thermocouples in weighing hopper Measures liquid temperatures in weighing hopper.
- Heater and thermal insulation cover for gear pump Maintains preset liquid temperature.
- Heater and thermal insulation cover for flexible hose Maintains preset liquid temperature.
- Heater and thermal insulation cover for weighing hopper Maintains preset liquid temperature.

#### 选配装置

- 搅拌器 搅拌计量罐内液体使其温度均衡。
- 移动脚踏带止动 把送料机本体作成移动式时使用。
- 一体式控制盘 送料机本体与控制盘一体化。
- 液体投入泵 从储液罐把液体投入计量罐。

#### Optional devices

- Agitator Agitates liquid in weighing hopper for uniform temperature distribution.
- Caster type dolly (with stopper) Equipped to make unit portable.
- Unitized control panel Unit main body and control panel are unitized.
- Liquid supply pump Supplies weighing hopper with liquid from drum.

### 组合柱塞泵使用例(流量、供液压力可另行对应)

Practical example equipped with plunger pump (Different flow rates and discharge pressures are available separately.)

|                             |  |   |
|-----------------------------|--|---|
| 使用材料<br>Applicable material | 纯水<br>Demineralized water                    | 比重:1<br>粘度:1cP<br>液温:常温<br>Specific gravity:1<br>Viscosity: 1 cP<br>Liquid temperature:<br>room temperature |
| 流量范围<br>Flow rate range     | 4~25kg/h                                     |   |
| 供液压力<br>Discharge pressure  | 7MPa   |   |
| 料斗容量<br>Hopper capacity     | 50L  |   |
| 称量<br>Weighing capacity     | 60kg   |   |
| 产品重量<br>Feeder weight       | 约250kg<br>Approximately 250 kg               |   |
| 电源<br>Power supply          | AC220V 3相2.5KVA<br>200V AC, 3 phase, 2.5 kVA |   |

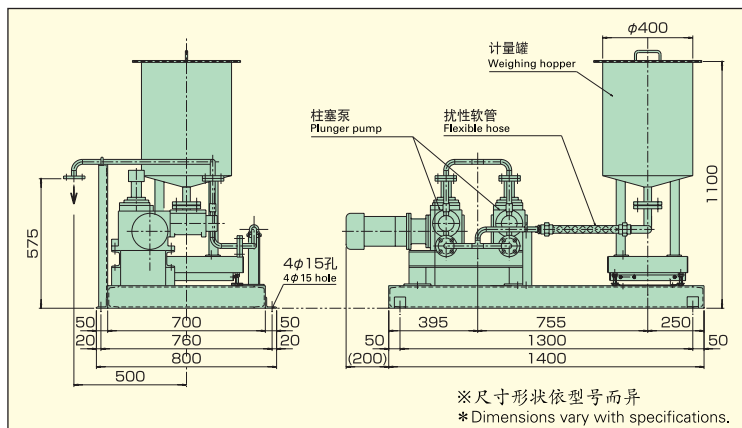

提案  
 CE-VV  
 CE-T  
 CE-M  
 CE-S  
 CE-R  
 CE-B  
 CE-V  
 大型称量型送料机  
 Large Weighing Feeder  
 LWF  
 B-WF  
 控制系统  
 Control System  
 选配件  
 Options  
 PLATON II